



NEW!

Comfort 2^{INSIDE}

Looking for a system which gives you the following benefits:

- Good overview
- Easy access to feed, water and nests
- Enhanced sanitation
- More 1st class eggs
- Low percentage outside nest eggs
- Easy to maintain

Then the Comfort 2^{INSIDE} aviary system is just what you are looking for!

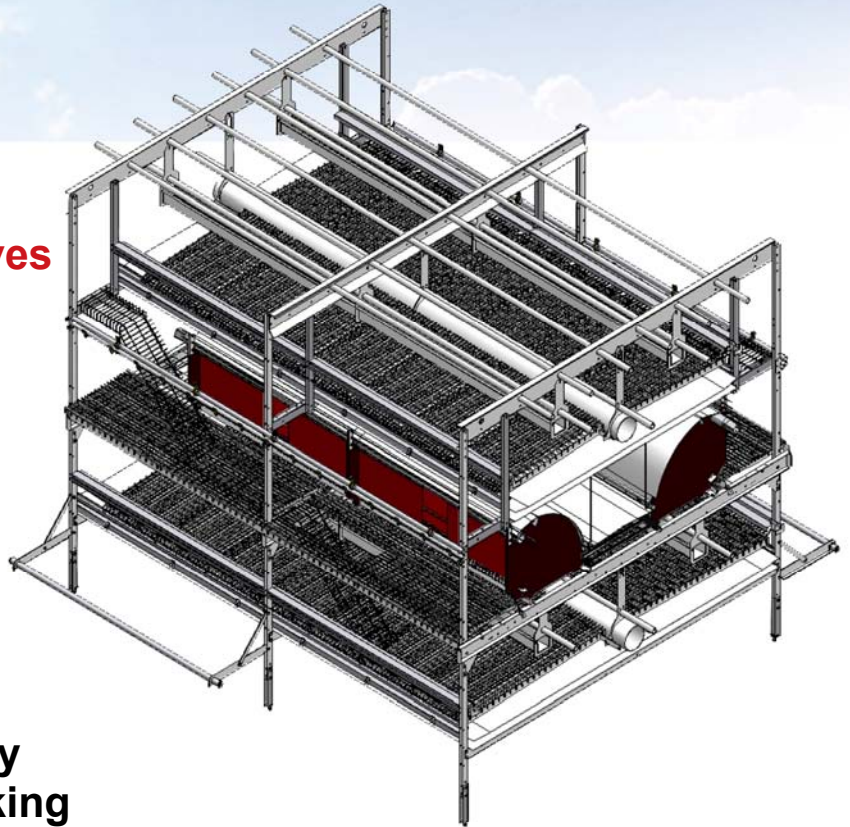

The system has the same basic design as the Compact and Comfort 2 aviary systems and has been developed so that the birds can move easier among the different tiers of an aviary row.

Stairs have been incorporated between the different tiers which enhances the bird movement within an aviary row. Feed, water and nest can be easily reached.

Fly-on platforms along the aviary system aren't necessary any more. Every 1.5 m foldable perches are placed along the aviary.

Design:

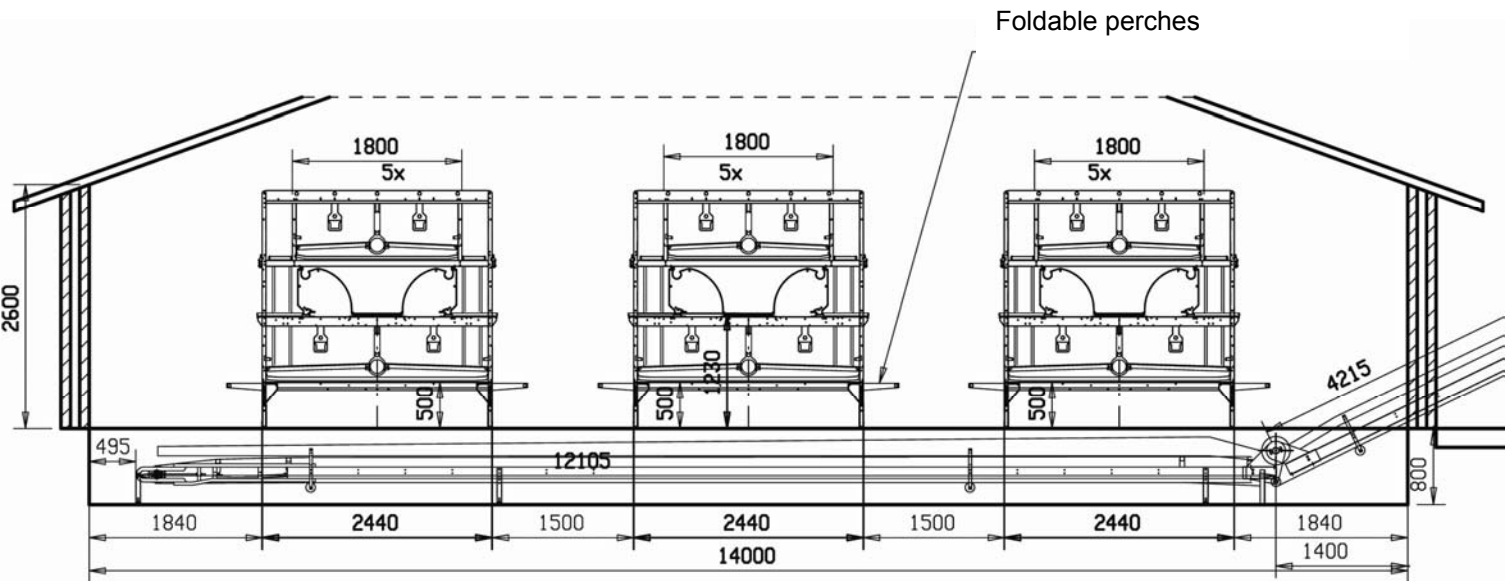
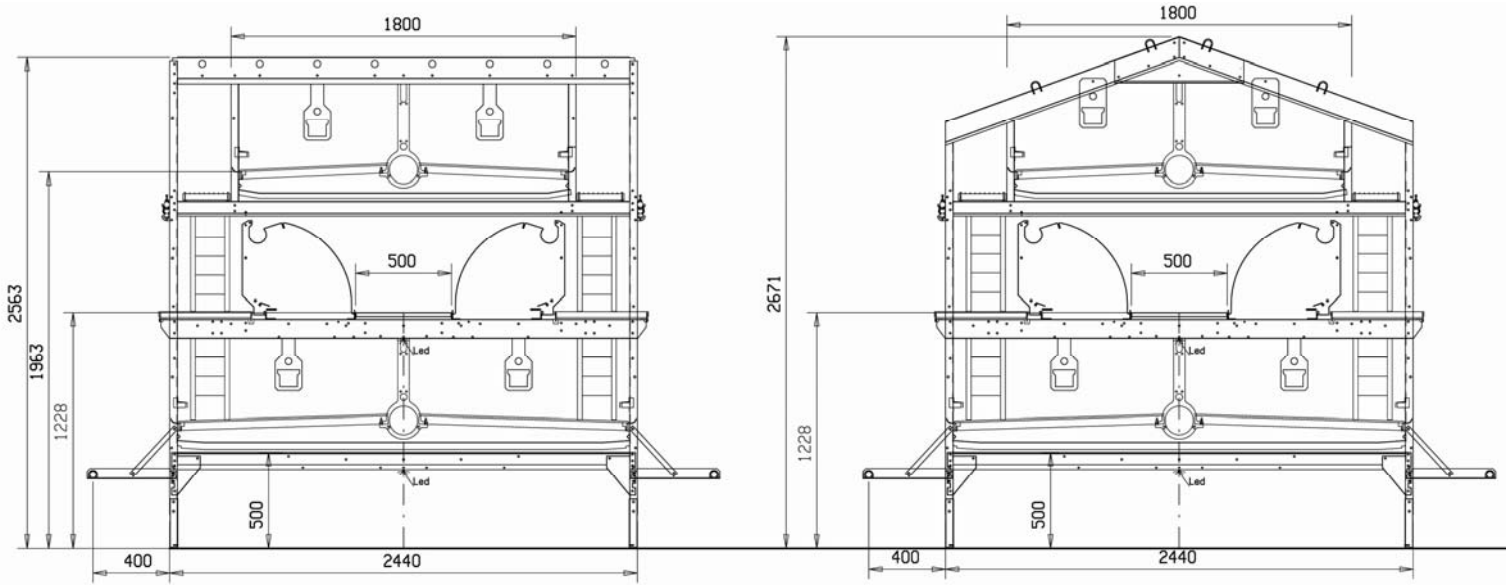

House 75 x 14 for ca. 17.000 leghennen

